

Historical View on Ergot Alkaloids

A. Hofmann

Key Words. Ergonovine · Ergot · History · Hydergine · Methergine

Abstract. A short survey of the history of ergot, of the original and, for a long time, only source of ergot alkaloids, is given. Once a dreaded poison, ergot has changed its role over the centuries to become a rich treasure house of valuable pharmaceuticals. In the Middle Ages it was the cause of epidemics of ergotism, which cost tens of thousands of people their lives. Ergot was first mentioned by the German physician *Lonitzer* in 1582 as a remedy used by midwives for quickening childbirth. The isolation of pharmacologically useful alkaloids started in 1906 with the discovery of ergotamine and its adrenolytic activity by *Barger, Carr* and *Dale*. In 1918, *Stoll* isolated ergotamine, the first chemically pure ergot alkaloid, which found widespread therapeutic use in obstetrics and internal medicine. In 1935 the specific oxytocic principle of ergot, ergonovine, was discovered simultaneously in four separate laboratories. Since then, worldwide investigations on ergot alkaloids resulted in the elucidation of their structures and total syntheses and preparation of valuable therapeutics such as Methergine, Hydergine, Dihydergot, and others.

Short History of Ergot

The original and, for a long time, only source of ergot alkaloids was the sclerotium of the fungus *Claviceps purpurea* (Fries) Tulasne, which grows on rye and which is commonly known as ergot (*Secale cornutum*) (fig. 1).

Ergot has a fascinating history. Over the centuries its role and significance have undergone a complete metamorphosis. Once a dreaded poisonous contaminant, it has changed to become a rich treasure house of valuable pharmaceuticals.

Ergot began its history as a poisonous contaminant of edible grain. As early as 600 BC, an Assyrian tablet alluded to a 'noxious pustule in the ear of grain'. In the Middle Ages, bizarre epidemics occurred in Europe which cost tens of thousands of people their lives, caused by bread made from rye contaminated with ergot. These epidemics of ergotism occurred in two forms, as *Ergotismus convulsivus* which was characterized by nervous, convulsive symptoms, and as *Ergotismus gangraenosus* in which gangrenous manifestations leading to mummification of the extremities were a prominent



Fig. 1. Ergot (*Secale cornutum*).



Fig. 2. St. Anthony surrounded by patients stricken with ergotism. (Staatliche graphische Sammlung, München.)

feature. Ergotismus was also known as 'ignis sacer', 'holy fire' or 'St. Anthony's fire', because St. Anthony was the patron saint of a religious order, which was founded for the purpose of caring for the victims of ergotism. Figure 2 shows St. Anthony surrounded by patients stricken with ergotism. The cause of these epidemics, i.e., bread contaminated with ergot, was recognized as late as in the 17th century, and since then there have been only sporadic outbreaks of ergot poisoning.

Ergot was first mentioned by the German physician *Adam Lonitzer* in 1582 as a remedy used by midwives for quickening childbirth.

The first scientific report on the use of ergot as an oxytocic agent, 'Account of the pulvis parturiens', was given by the American physician *John Stearns* in 1808. But already in 1824, *D. Hosack*, recognizing the danger of using ergot for accelerating childbirth, recommended that the drug be used only to control postpartum hemorrhage. Since that time ergot has been used in obstetrics mainly for this purpose.

The last and most important chapter in the history of ergot, and one which is still not completed, concerns ergot as a rich source of pharmacologically useful alkaloids.

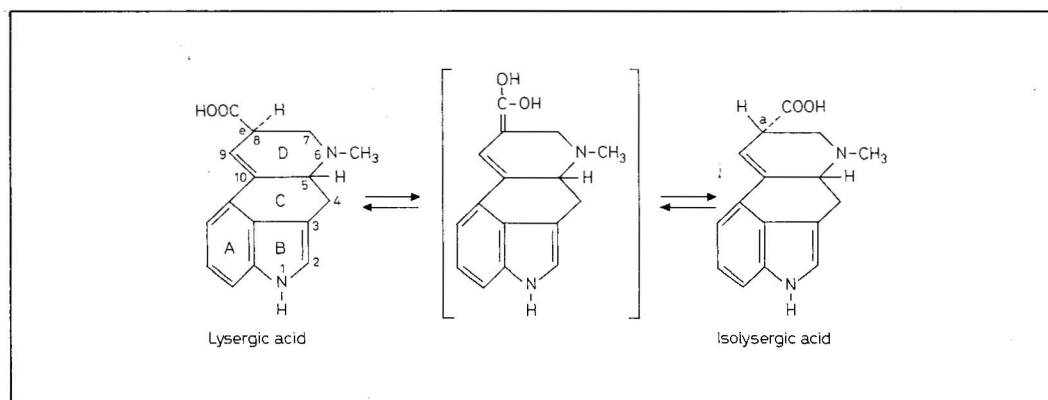

Fig. 3. Lysergic and isolysergic acid.

The Most Important Steps of Chemical Investigations of Ergot Alkaloids (1, 2)

It started with the isolation of ergotamine in 1906 by *Barger* and *Carr* and the discovery of its adrenolytic activity by *Dale*. In 1918, *Stoll* isolated ergotamine, the first chemically pure ergot alkaloid which found widespread therapeutic use in obstetrics and internal medicine.

The next important step was the discovery in 1935 of the specific oxytocic principle of ergot by *Dudley* and *Moir*, which resulted in the isolation of the alkaloid ergonovine (also named ergometrine, ergobasine, ergotocine) simultaneously in four separate laboratories.

Since 1935, extensive investigations on the chemistry of ergot alkaloids have been carried out, mainly by *Jacobs* and *Craig* in the United States, *Smith* and *Timmis* in England, *Stoll*, *Hofmann et al.* in Switzerland, paralleled by pharmacological and clinical investigations by *Rothlin*, *Cerletti et al.* The most important steps in these investigations were the following: identification of the common nucleus of all pharmacologically important ergot alkaloids by *Jacobs* and *Craig*, which they named lysergic acid, in 1934; discovery of isolysergic acid by

Smith and *Timmis* in 1936, isolysergic acid being the nucleus of the pharmacologically inactive isomers of ergot alkaloids; elucidation of the structure of lysergic and isolysergic acid by *Jacobs* and *Craig* and by *Stoll*, *Hofmann* and *Troxler*, which led to the final formula as depicted in figure 3, published in 1949.

This constitution of lysergic acid and isolysergic acid was confirmed by total synthesis by *Kornfeld et al.* in the Lilly Laboratories in 1954. A different synthesis of lysergic acid was published by *Julia et al.* in 1969. Both syntheses are only of scientific interest; they cannot compete with the production of lysergic acid from natural sources.

Lysergic acid, possessing two asymmetric centers, can exist in four stereoisomeric forms: *d*-lysergic acid, *d*-isolysergic acid, *l*-lysergic acid and *l*-isolysergic acid. With very few exceptions, only the alkaloids or synthetic derivatives containing *d*-lysergic acid show the high characteristic pharmacological activity.

The first partial synthesis of a natural ergot alkaloid, namely of ergonovine, could be realized by *Stoll* and *Hofmann* in 1937, by connection of lysergic acid in the form of its reactive azide with *L*-2-amino-propanol (fig. 4).

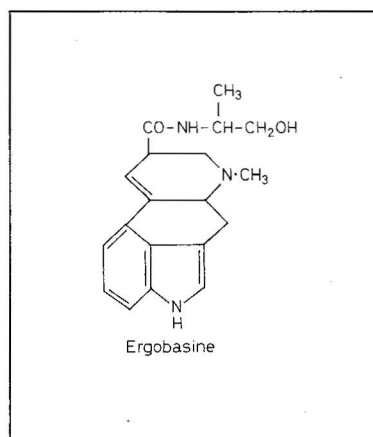

Fig. 4. Structure of Ergobasine (synonyms Ergonovine, Ergometrine).

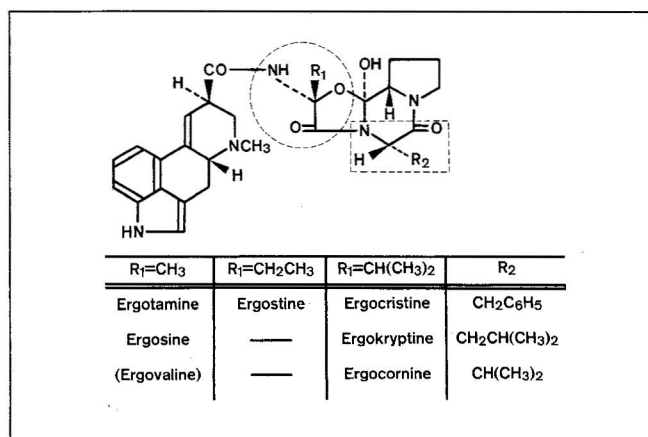

Fig. 5. Structural formulae of peptide ergot alkaloids.

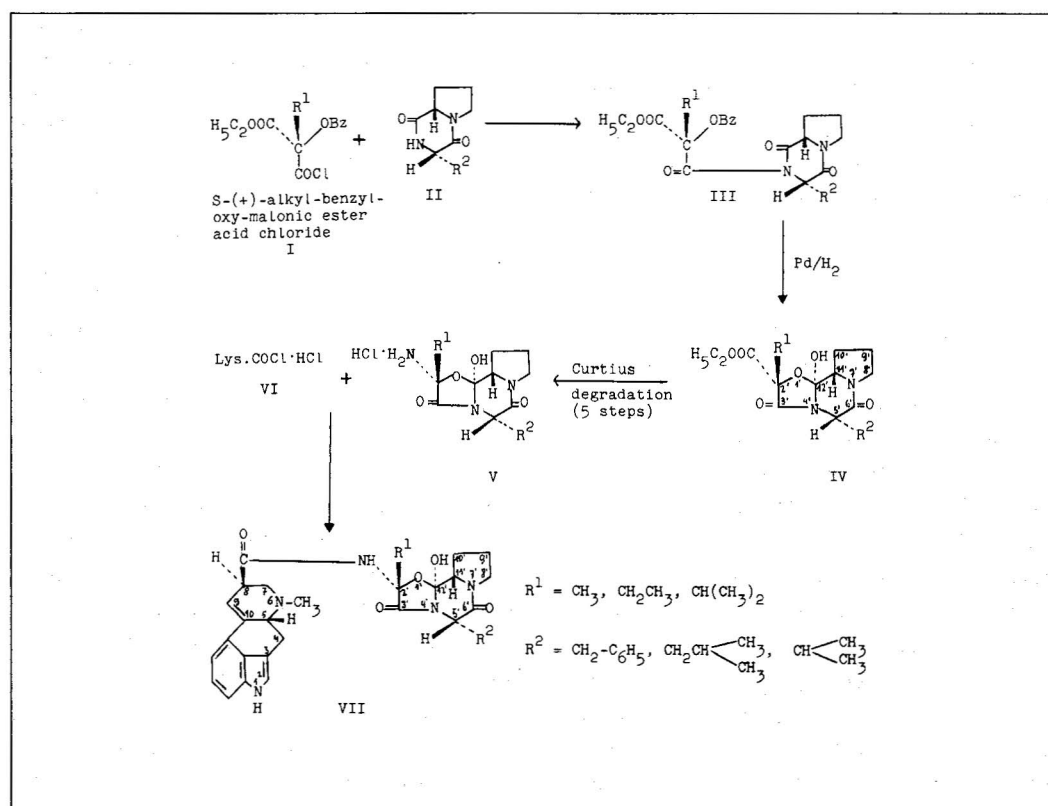

Fig. 6. Synthesis of peptide type ergot alkaloids.

This method of synthesis was used for the preparation of a large number of amides of *d*-lysergic acid of the type of ergonovine and of other simple amides which will be discussed later.

An important discovery, published by *Stoll and Hofmann* in 1943, was the observation that ergotamine, as described by *Barger and Carr* in 1906, is not a chemical entity, but an extremely variable mixture of three alkaloids which we named ergocristine, ergokryptine and ergocornine. Later we found that ergokryptine occurs in two isomeric forms, designated as α - and β -ergokryptine.

It was only in 1951 that the complete chemical structure of ergotamine and of the alkaloids of the ergotamine group became known. The elucidation of the structure of the peptide part of these so-called peptide-type alkaloids had taken us many years of chemical and physicochemical investigations. Figure 5 represents the chemical constitution of the peptide ergot alkaloids, published by *Stoll, Hofmann and Petrzilka* in 1951.

The constitution of the peptide part, which is built up by three amino acids, is characterized by a so-called cyclol structure, a structural element not known until then in organic chemistry. The alkaloids of the ergotamine and ergotamine group differ from each other by variation of the amino acid radicals. Common to all peptide alkaloids is the amino acid *L*-proline.

These structures of the peptide type ergot alkaloids were confirmed 10 years later by the total synthesis of ergotamine by *Hofmann, Frey and Ott* in 1961 (fig. 6).

Here, in a pharmacological-medical audience, is not the place to discuss the various steps of this fascinating piece of synthetic organic chemistry. This would provide the subject of a lecture of its own.

The synthetic procedure developed for the synthesis of ergotamine could be used also for the synthesis of all other alkaloids of the peptide type and was worked out by *Stadler et al.* to a procedure which can be used, and is used today, for the synthetic production of these alkaloids on an industrial scale.

After these main achievements of chemical research on ergot alkaloids, I should like to complete the picture by discussing briefly some additional results.

Besides the alkaloids already mentioned, a variety of minor alkaloids have been isolated in our and in other laboratories. Figure 7 provides a survey on the various types of ergot alkaloids.

Whereas the classical ergot alkaloids are amides of lysergic acid, many of the minor alkaloids belong to the so-called clavine type of ergot alkaloids. In this type the carboxyl group of lysergic acid is reduced to a hydroxymethyl or to a methyl group.

Up to the present, some 40 ergot alkaloids, including the isomeric forms, have been isolated from natural sources. Until now, none of the minor alkaloids has found special pharmacological interest.

New Sources of Ergot Alkaloids

Here follow some remarks on new sources available today for the production of ergot alkaloids. As already mentioned, ergot of rye was for a long time the only source of these alkaloids. When the naturally occurring ergot collected on the rye fields was no longer sufficient for the preparation of ergot pharmaceuticals, methods for artificial inoculation of rye on an industrial scale were developed first by *Bekesy* in Hungary and by *Brack* in Switzerland (fig. 8).

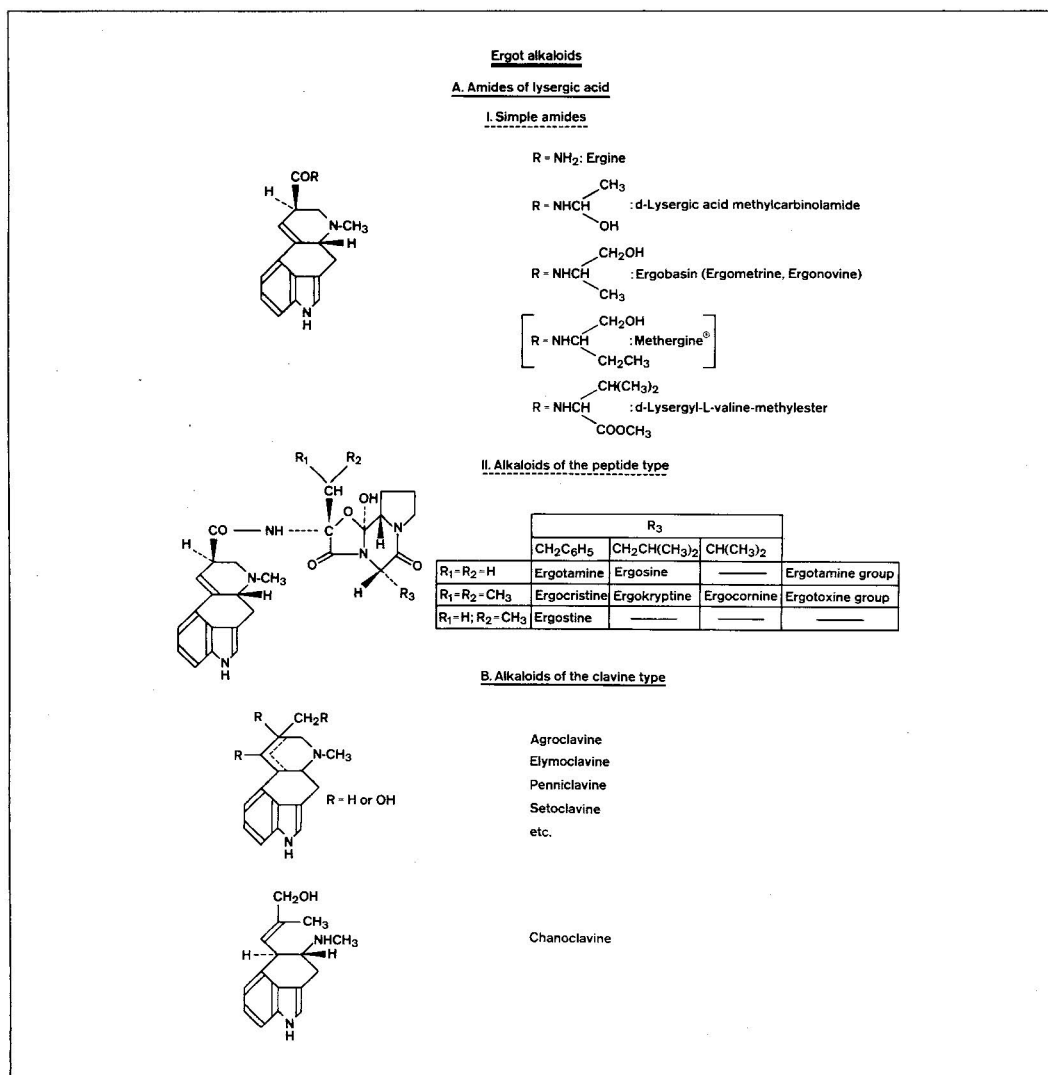

Fig. 7. Survey on the various types of natural ergot alkaloids.

A large percentage of ergot alkaloids used today is still extracted from ergot cultivated on artificially inoculated rye fields. But more and more important becomes the industrial production of ergot alkaloids in submerged cultures of certain strains of the ergot fungus in tank procedures. In 1960 Arcamone *et al.*, at the

'Istituto Superiore di Sanità' in Rome, discovered an Italian strain of *Claviceps paspali* which was able to produce lysergic acid amide and simple derivatives of lysergic acid amide in high yield in submerged culture. In 1964, Kobel, Schreier and Rutschmann of the Sandoz Laboratories succeeded in isolating from ergot grown on the wild grass *Paspalum dilatatum* a claviceps strain capable of producing excellent yields of a mixture of free lysergic acid isomers,



Fig. 8. Artificial inoculation of a rye field with the ergot fungus.

mainly paspalic acid, which can easily be transformed into lysergic acid (fig. 9). This provides the possibility to produce lysergic acid on an industrial scale, in tanks, independent from ergot grown on rye fields. Lysergic acid itself can be used then as starting material for the synthesis on an industrial scale of pharmaceutical ergot preparations.

The strains of *Claviceps purpurea*, more recently discovered in the Sandoz Laboratories and by Farmitalia, provide a further source for the production of medicinally used ergot alkaloids. These strains are able to produce, in submerged culture, ergot alkaloids of the peptide type, such as ergotamine or the alkaloids of the ergotamine group (3).

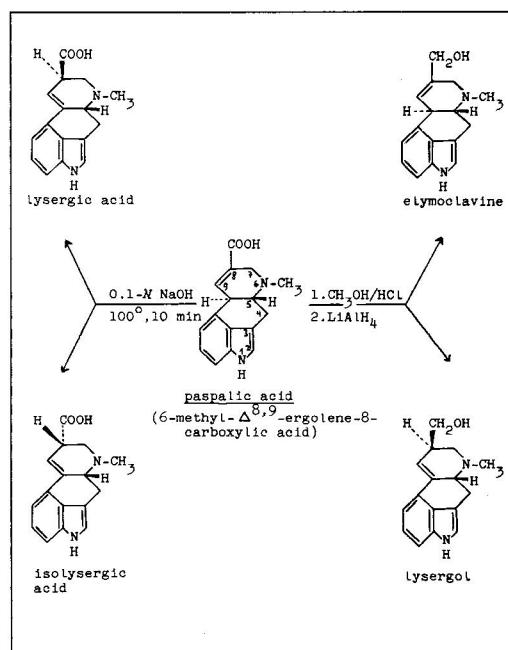

Fig. 9. Paspalic acid and its isomers.

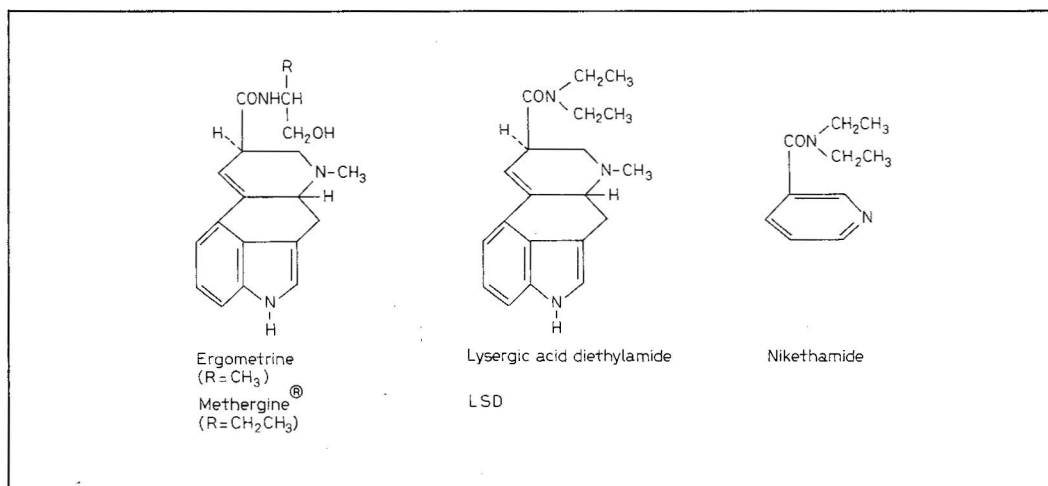

Fig. 10. Modifications in the side chain of ergonovine (ergometrine).

Another, quite unexpected source of ergot alkaloids was discovered in 1960 by *Hofmann* and *Tscherter*. They found in the old magic Mexican drug *ololiuqui*, which is the Aztec name for the seeds of certain Morning Glory species, lysergic acid amide, lysergic acid-hydroxyethylamide, closely related to lysergic acid diethylamide (LSD), and other lysergic acid derivatives. But this source is only of phytochemical, not of practical interest.

Chemical Modifications of Natural Ergot Alkaloids and of Synthetic Derivatives with Interesting Pharmacological Activity

Hundreds of chemical modifications and synthetic variations of ergot alkaloids have been prepared in our and in other laboratories. Only the most important derivatives with interesting pharmacological properties can be discussed here.

Ergot alkaloids have an astonishingly wide spectrum of action, a multiplicity of different pharmacological activities, such as is rarely found in any other group of natural products: peripheral effects on blood vessels and on the

uterus; neurohumoral effects influencing the action of adrenaline, serotonin and dopaminergic structures; central effects on the vasomotor center in the medulla oblongata and on sympathetic centers in the midbrain, particularly in the hypothalamus.

The difference in biological activity of the various structural types of ergot alkaloids and derivatives results from the fact that the relative predominance of these main effects varies from compound to compound. One or more of these activity components may be almost completely absent, other effects may remain unaltered or may even be enhanced. The goal of chemical modifications is to arrive at compounds with a narrower range of activity with more selective, more specific effect.

The first modifications of a natural ergot alkaloid became possible and were carried out after the development of a partial synthesis of ergonovine, the specific oxytocic factor of ergot, which I have already mentioned. It provided the possibility to replace the alka-

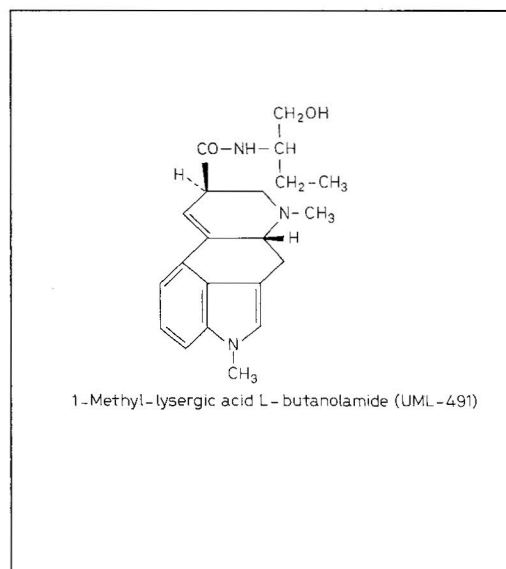
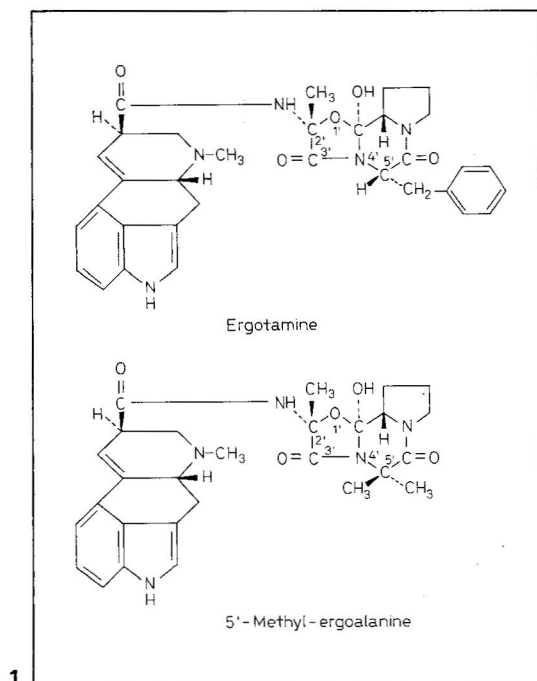

Fig. 11. Structural formula of 5'-methyl-ergoalanine.

Fig. 12. Structural formula of Methysergide.

nolamine side chain of the natural alkaloid by other amines (fig. 10).

Among the synthetic homologues of ergonovine, the next higher homologue, i.e., the *L*-butanolamide of *d*-lysergic acid, proved to be superior in its pharmacological properties to the natural alkaloid. It is used today worldwide with the brand name 'Methergine' in obstetrics to stop postpartum hemorrhage.

Within this series of simple synthetic amides of lysergic acid, I also prepared *d*-lysergic acid diethylamide which became famous as a specific, extraordinary potent hallucinogen under the laboratory code name LSD.

Modifications in the side chain of the peptide alkaloids by synthetic introduction of other amino acids than those contained in the natural alkaloids produced interesting changes in the activity spectrum. Out of the many compounds of this type synthesized in our

laboratories only two may be mentioned. Replacing *L*-phenylalanine in ergotamine by α -methylalanine, a new peptide, called 5'-methyl-ergoalanine, was obtained (fig. 11). Compared with ergotamine, its vasoconstriction power is 50% higher, while its uterotonic and its emetic activity are many times weaker. On replacing *L*-phenylalanine by *O*-methyl-*L*-tyrosine, 5'-*p*-methoxy ergotamine was obtained, which proved to be a specific uterotonic agent.

A very effective chemical modification is alkylation, principally methylation at the position 1 of the lysergic or dihydrolysergic ring system. This leads to compounds with enhanced specific antiserotonin activity. From the large number of 1-methyl ergot derivatives studied as serotonin antagonists, we have selected for introduction into therapy 1-methyl-lysergic acid *L*-butanolamide (fig. 12).

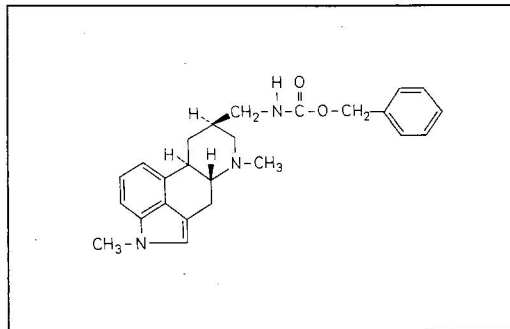

Fig. 13. Structural formula of MCE.

Generic name: Methysergide. It is used for prophylactic treatment of migraine.

Another 1-methyl derivative with similar activity was described under the laboratory code name MCE by *Fregnan and Glässer* (fig. 13).

A fundamental change in pharmacological actions occurred when the double bond at the positions 9, 10 in the lysergic acid moiety of the peptide alkaloids was saturated with hydrogen. The vasoconstrictor and uterotonic actions, the classical effects of ergot, and the stimulation of central sympathetic structures, are greatly attenuated in the dihydro derivatives; the activity of the vasomotor center is reduced, whereas the sympatholytic-adrenolytic effects are specifically enhanced. The dihydro derivatives of ergotamine and of the alkaloids of the ergotamine group, i.e., dihydro-ergocristine, dihydro-ergokryptine and dihydro-ergocornine, which were published by *Stoll and Hofmann* in 1943 and investigated pharmacologically by *Rothlin, Cerletti et al.* (4, 5) proved to be very interesting pharmaceutical agents. Dihydro-ergotamine was introduced into therapy for the treatment of orthostatic disorders. Dihydro-ergotamine has become a valuable medicament in geriatrics. New findings concerning the pharmacodynamic actions of

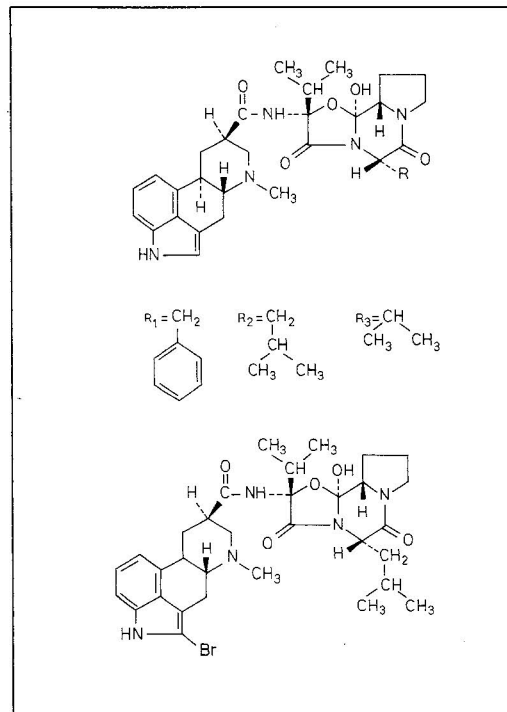

Fig. 14. Chemical structures of the dihydro-ergotamine alkaloids and of 2-bromo- α -ergokryptine.

dihydro-ergotamine will play an important role in the discussions of this meeting.

There would be many other pharmacologically interesting modifications of ergot compounds which have been prepared in our and in other laboratories, but time allows me to mention only a last ergot modification, which plays also a role in the discussions of this meeting. This modification consists of the bromination at the position 2 of the lysergic acid molecule. Introduction of halogen, particularly bromine, in lysergic acid derivatives was first published by *Troxler and Hofmann* in 1957.

One of the first bromo-derivatives which we prepared was 2-bromo-LSD. Compared with LSD it showed a quite different activity spec-

trum. The high hallucinogenic activity of LSD has disappeared. The outstanding pharmacological property of 2-bromo-LSD is its specific antiserotonin activity.

Another of our many 2-bromo-derivatives was 2-bromo- α -ergokryptine (fig. 14).

Certain endocrinological effects of peptide ergot alkaloids, studied more recently, connected with a dopamine agonist action are specifically enhanced in this compound.

To close my survey I would repeat what I said already at the beginning of my talk, that ergot is an extraordinary rich source of valuable pharmaceuticals, which is, as the presentations of this meeting will prove, still not yet exhausted.

References

- 1 Hofmann, A.: Die Mutterkornalkaloide (Enke, Stuttgart 1964).
- 2 Stalder, P.A. and Stuetz, P.: The ergot alkaloids; in Manske, The alkaloids, vol. 15, pp. 1-40 (Academic Press, New York 1975).
- 3 Kobel, H.: Möglichkeiten zur fermentativen Herstellung von Mutterkornpeptidalkaloiden. Chem. Rdsch. 27: 57-59 (1974).
- 4 Rothlin, E.: The pharmacology of the natural and dihydrogenated alkaloids of ergot. Bull. Acad. suisse Sci. méd. 2: 1-24 (1946/47).
- 5 Bircher, R. und Cerletti, A.: Pharmakodynamische Grundlagen der Therapie von Kreislaufstörungen mit den Dihydroalkaloiden des Mutterkorns. Helv. med. Acta, suppl. 22 (1949).

Dr. A. Hofmann, CH-4117 Burg i.L. (Switzerland)